

a

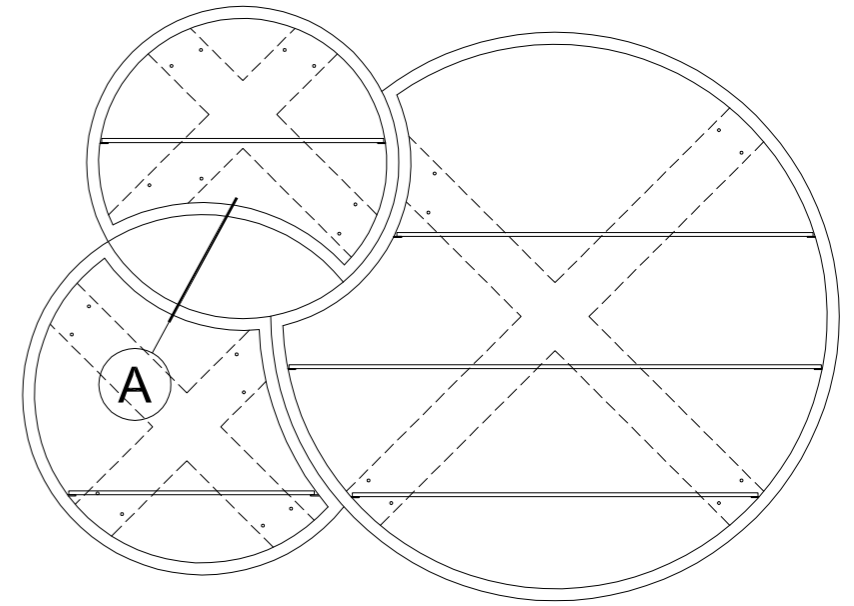

b

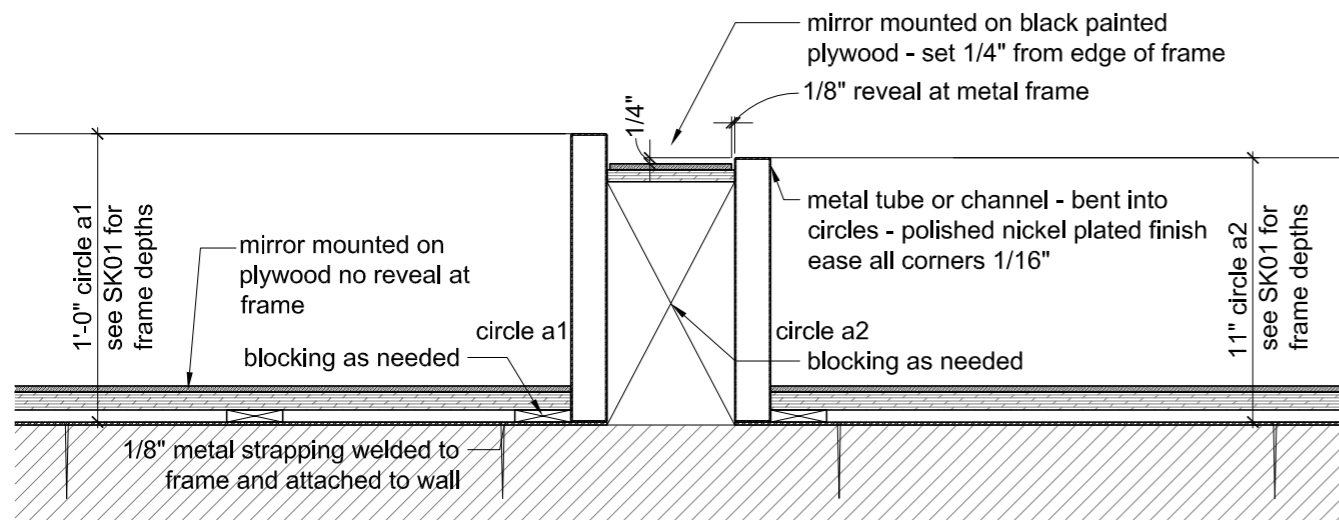

**A** details showing typical conditions at shelves and at shallow sections  
scale: 1 1/2" = 1'-0"

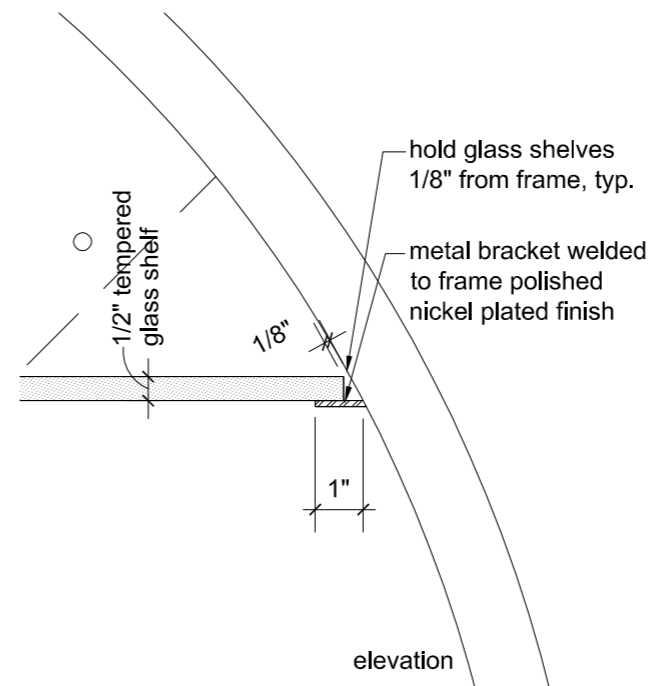

**B** detail at shelf brackets - elevation  
scale: 3" = 1'-0"

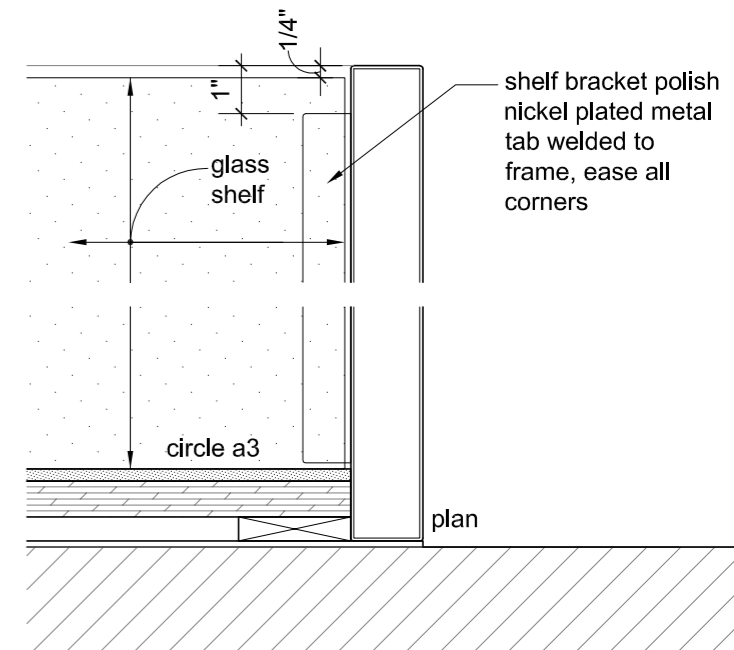

**B** detail at shelf brackets - plan  
scale: 3" = 1'-0"